

# Future Proof Machine Safety

*From regulation to practice*

Yuan Lee

Business Development Manager

December 2023

Sep Schraven

Key Account Manager



# Official announcement – regulation update

29.6.2023

EN

Official Journal of the European Union

L 165/1

I

*(Legislative acts)*

## REGULATIONS

**REGULATION (EU) 2023/1230 OF THE EUROPEAN PARLIAMENT AND OF THE COUNCIL**

**of 14 June 2023**

**on machinery and repealing Directive 2006/42/EC of the European Parliament and of the Council  
and Council Directive 73/361/EEC**

*(Text with EEA relevance)*



●  
● Machinebouw

12 december 2023, Congrescentrum 1931

# Industrial Revolutions

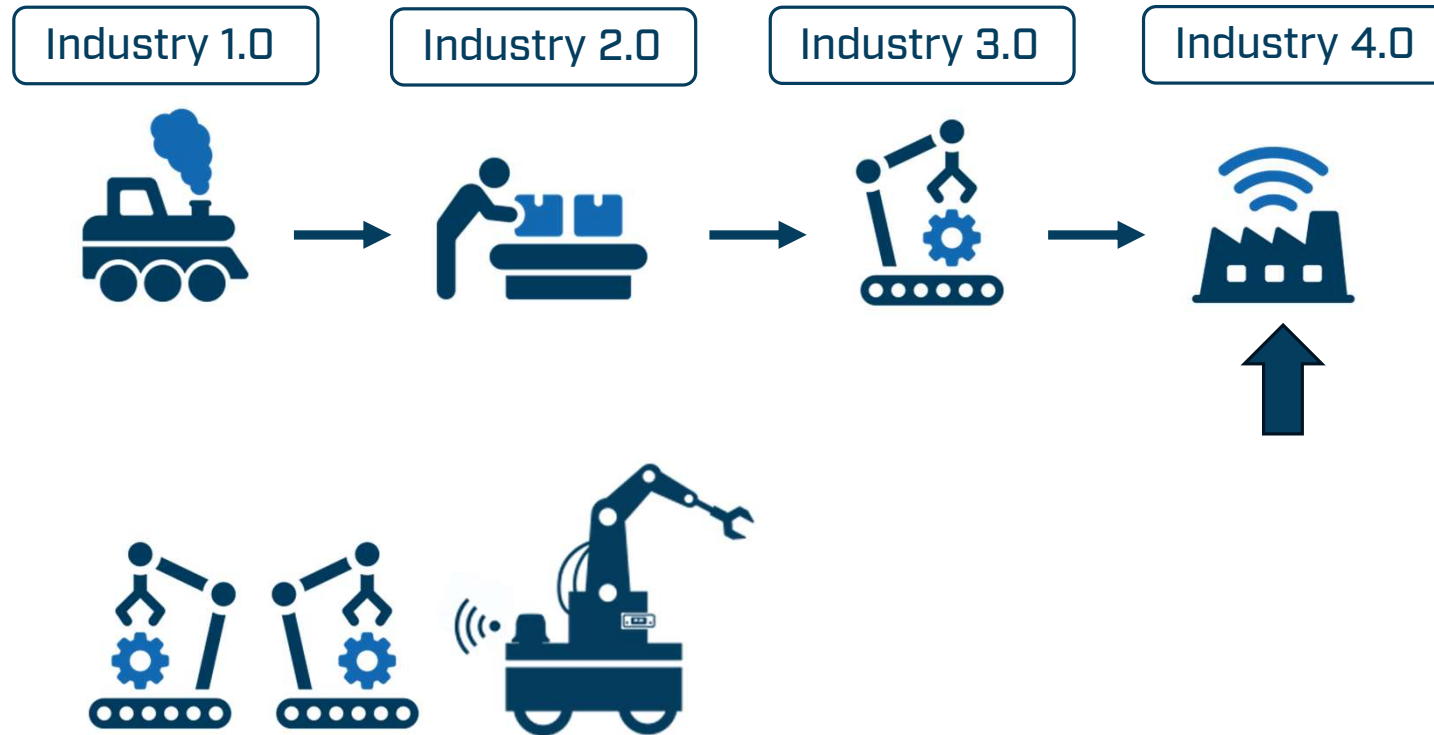

Machinebouw

12 december 2023, Congrescentrum 1931

# Increased flexibility, increased wireless controls

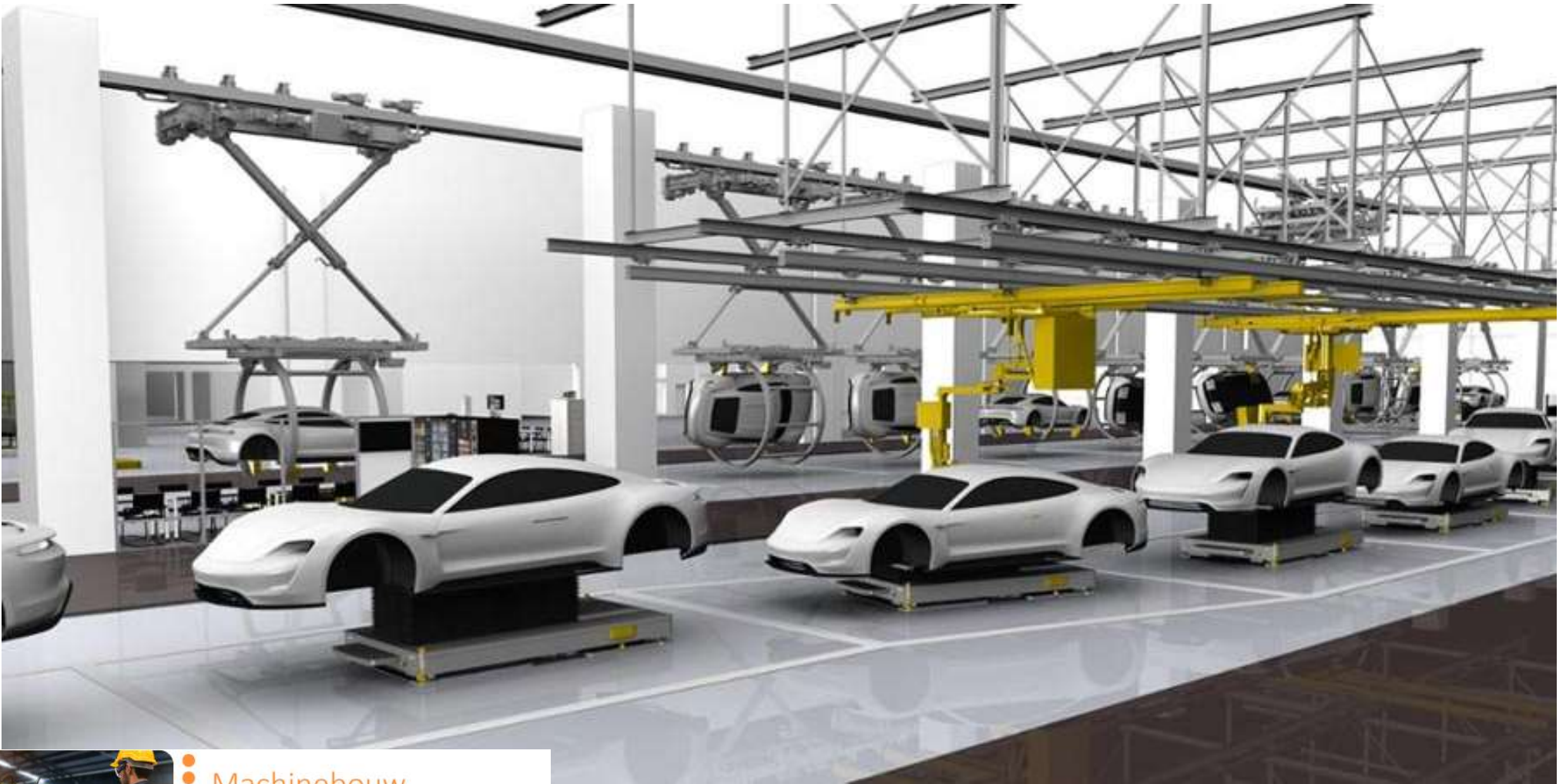

Machinebouw

12 december 2023, Congrescentrum 1931

# Increased flexibility, increased wireless controls

Didn't we forget something..

.. How to ensure human safety in these increasingly automated and complex environments?



# Industrial Revolutions

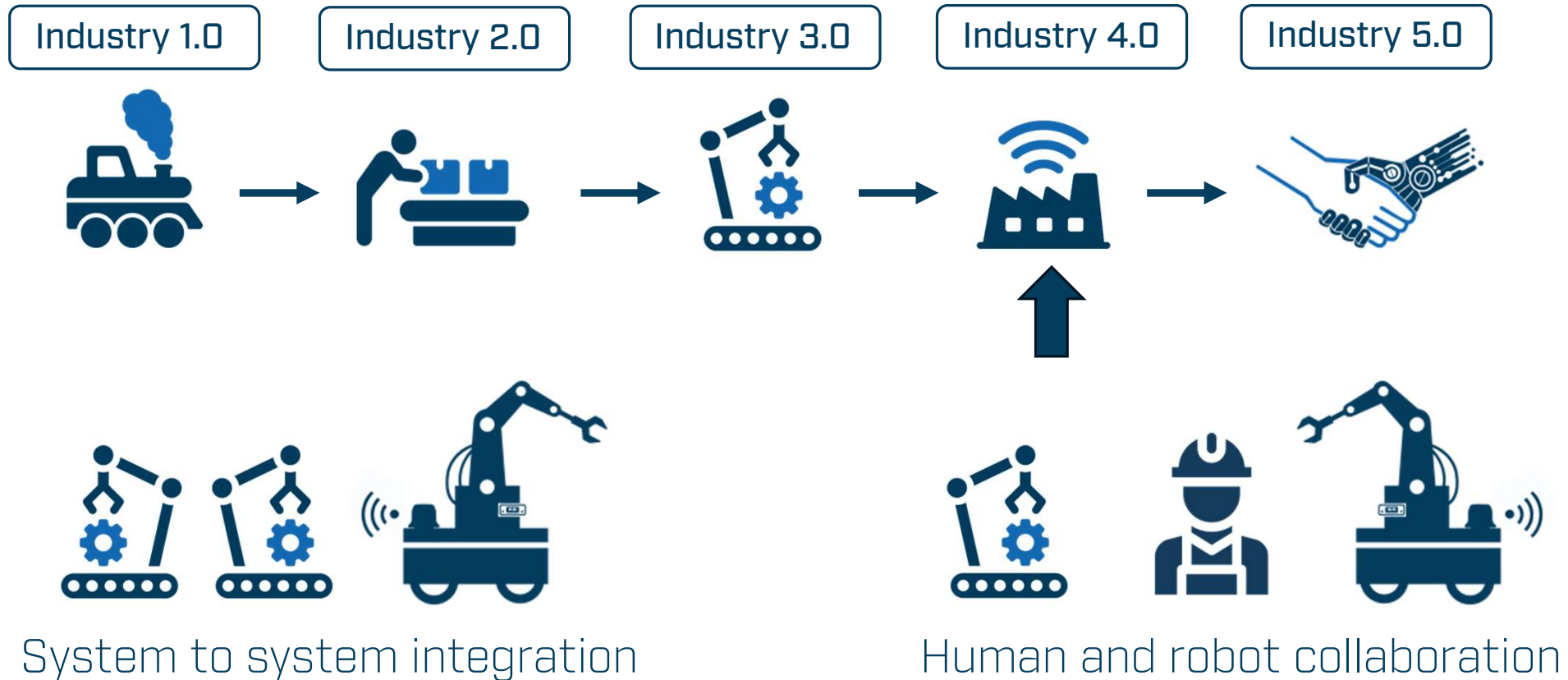

# New EU Machinery Regulation



Machinebouw

12 december 2023, Congressentrum 1931

Practically, how does the machine regulation  
impact machine and shopfloor?



Machinebouw

12 december 2023, Congrescentrum 1931



# Machine safety today

Safety control based on specific machines or part of machines.



Machinebouw

12 december 2023, Congrescentrum 1931

# Safety according to new machine regulation

Safety control based on *'machinery and related equipment if it's continuous operation may be dangerous'*

One 'Related Machinery' Safety Scope

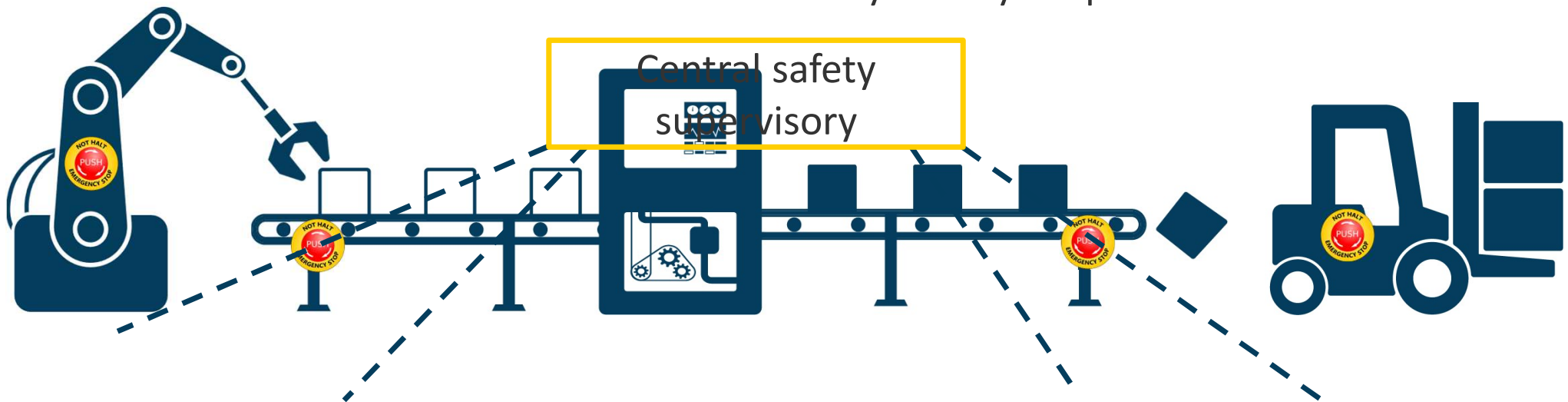

Machinebouw

12 december 2023, Congrescentrum 1931

# What to take into consideration for coming regulation?



Machinebouw

12 december 2023, Congrescentrum 1931

# Future Proof your Machine Systems

Cost

Engineering effort and resource

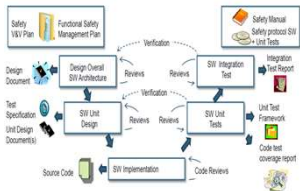

Modular design



Time

Time to market



Pre-certified



Value

Flexibility and interoperability

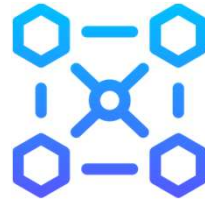

Scalable / multi-protocols

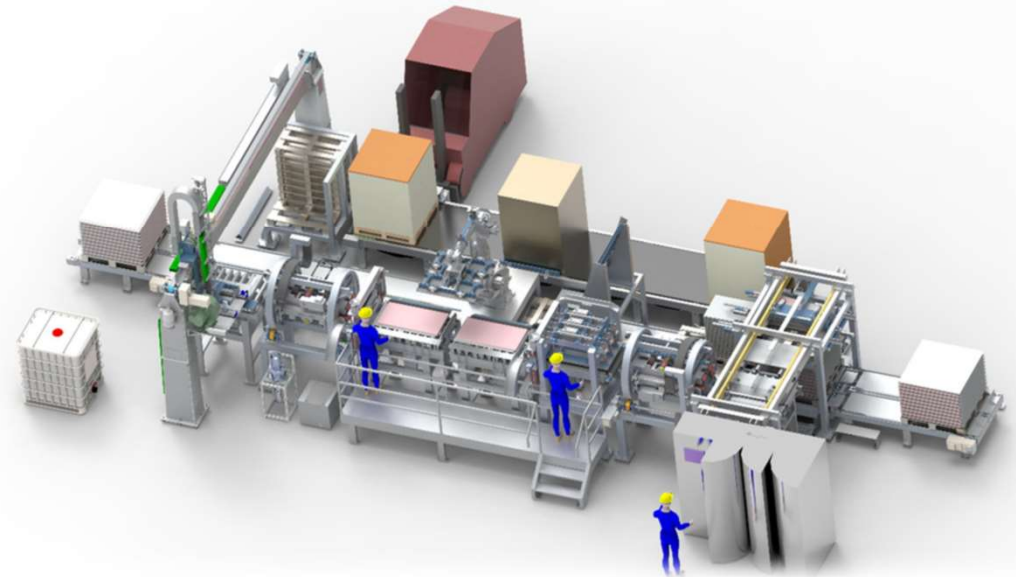

Machinebouw

12 december 2023, Congrescentrum 1931

# The Safebound



Machinebouw

12 december 2023, Congrescentrum 1931

# Seamless upgrade your safety system

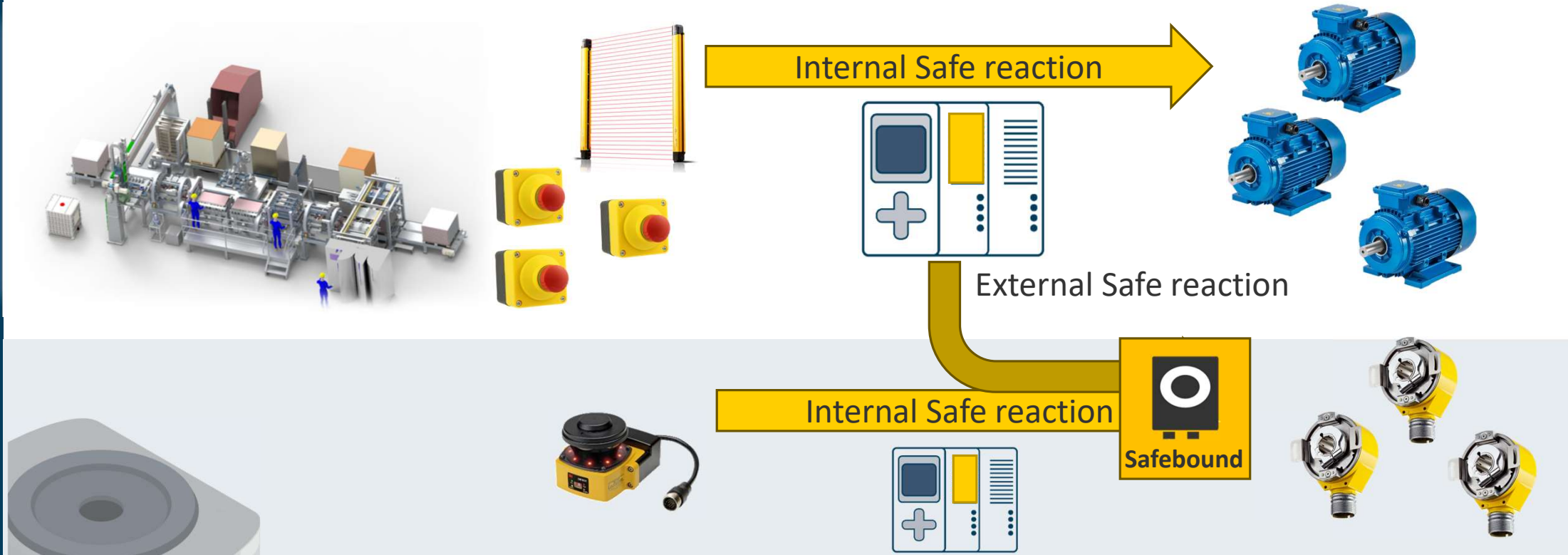

**Safebound:** Logic connection of two safe applications to one safe stop

- A Faster internal safety loop e.g. local safety sensors/logic
- A Slower external safety loop e.g. wireless emergency remote stop

But how can we deal with moving parts  
wirelessly?



Machinebouw

12 december 2023, Congrescentrum 1931

# The underlying layer - Protocols

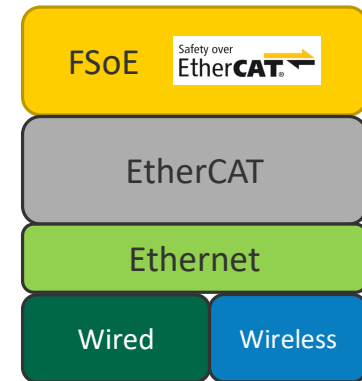
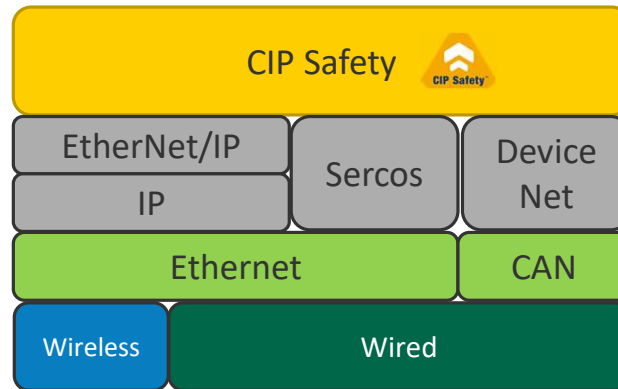
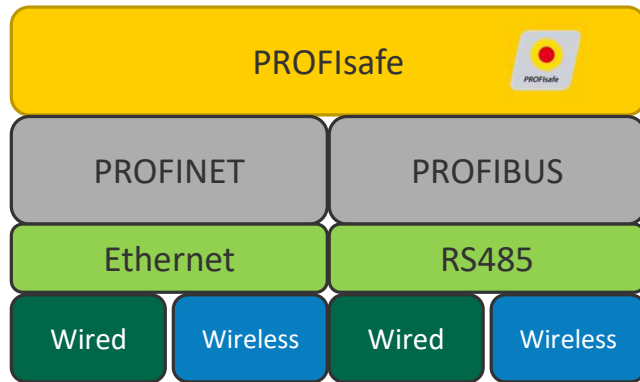

- Full duplex
- Timing / lower jitter
- Less packet loss
- Cost
- Durability



Wired

Wireless



- Half duplex
- Timing / higher jitter
- Higher packet loss
- Cost
- Durability



Machinebouw

12 december 2023, Congrescentrum 1931



# Adapting communication

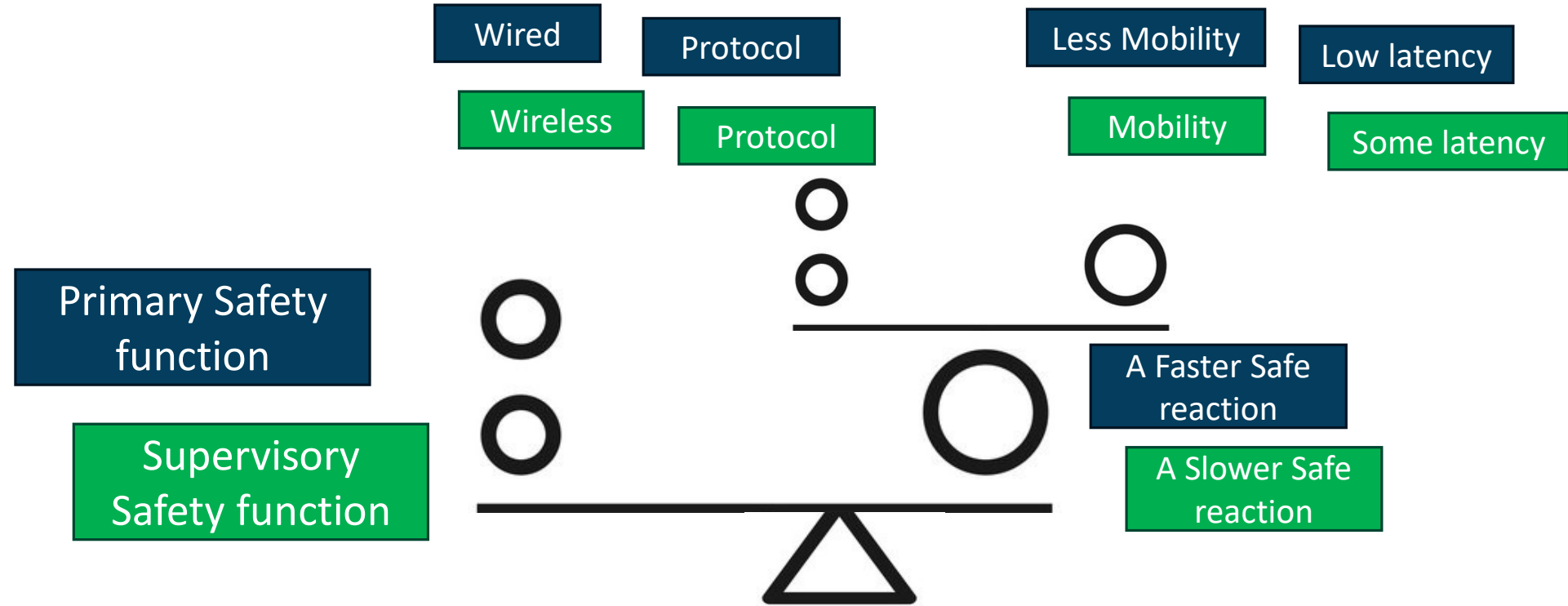

A Faster Safe reaction

A Slower Safe reaction



Machinebouw

12 december 2023, Congrescentrum 1931

Cycle time  
Re-try times

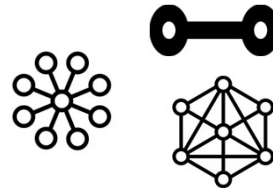

# The difference HMS makes



Machinebouw

12 december 2023, Congrescentrum 1931

# Implementation example - machine line

*Compliant according to machine regulation update*



Solution requirements:

1. (Wireless) connection
2. Safety client(s)

*Live demo at the HMS booth, number 3*



# Case study:



**Customer:**  
AMR Manufacturer



**Application:**  
Using HMS solution for remote e-stop which can be integrated with customers' safety infrastructure



## Why HMS?

- Pre-certified solution – fast time-to-market
- Wide range of support across different safety protocols
- Wireless solution for industrial protocols

*Live demo at the HMS booth, number 3*

# HMS at a glance

**+9,000,000**  
devices connected

**+400,000**  
machines connected  
to cloud systems

Our field:  
**Industrial ICT**  
(Information and  
Communication  
Technology)

**5G**  
Smart Grid  
**AI IoT** Wireless

At the forefront of  
**technology**

**800**  
employees  
worldwide



33% in R&D  
33% in Sales

Offices in **18**  
countries  
Partners in **50**



Head office in  
Halmstad, Sweden

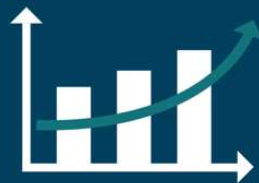

2022 sales  
**€225 MLN**



CO2 Net  
Positive in  
2025



Goal:  
Annual growth  
**20%**



# Key take-aways

1. New EU regulation accepted, valid from 2027, as part of CE certificate
2. Safety supervisory is introduced in the regulation update
3. Safebound is THE solution for direct internal safety loop and delayed (wireless) external safety loop
4. Wired or wireless? → Do your homework 😊
5. Don't re-invent the wheel, dare to ask!

*Live demo at the HMS booth, number 3*



# Questions?

Let's contact:

Sep Schraven  
Key Account  
Manager



Yuan Lee  
Business  
Dev. Manager



Please visit us at HMS booth,  
number 3, close to the entrance!



Machinebouw

12 december 2023, Congrescentrum 1931



Hardware Meets Software™

Let's contact:

Sep Schraven  
Key Account  
Manager



Yuan Lee  
Business  
Dev. Manager



Stay Connected!  
[www.hms-networks.com](http://www.hms-networks.com)

Please visit us at HMS booth,  
number 3, close to the entrance!