

# De volgende stap in het modulair en flexibel bouwen van machines

Melroy Boogaard - Murrelektronik



Machinebouw

12 december 2023, Congrescentrum 1931

# Even voorstellen

## WIE ZIJN WIJ

- Specialist in decentrale automatisering

## WAT DOEN WIJ

- Ontwikkelen en produceren hoogwaardige producten voor elektrische en elektronische machine- en fabrieksinstallaties.
  - Aansluittechniek
  - Elektronica in de schakelkast
  - Interfaces
  - I/O systemen



Machinebouw

12 december 2023, Congrescentrum 1931



# Branches

Opslag- en transporttechniek



F&B en Verpakking



Gebouwtechniek



Mobiele Machines

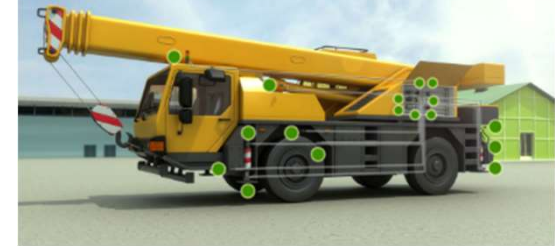

Automotive



Werktuigmachines



Airport Logistics

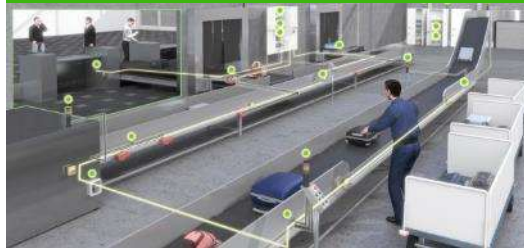

## Machinebouw

12 december 2023, Congrescentrum 1931

# De historie van de machinebouw

Disruptie van vervoer

New York City 5th Avenue

# 1900

Waar is de auto?



Machinebouw

12 december 2023, Congrescentrum 1931

Disruptie van vervoer

Herhaalt de geschiedenis zich?

New York City 5th Avenue

# 1900

Waar is het paard?



Machinebouw

12 december 2023, Congrescentrum 1931

# Wat is modulair bouwen?

Machines worden ontworpen en gebouwd als een **samenstelling van verschillende modules of componenten.**



● ● ● Machinebouw

12 december 2023, Congrescentrum 1931

# Oplossing op maat met modulair bouwen



Sportuitvoering



Soort lak



Entertainment  
systemen



Bekleding



Travelpack

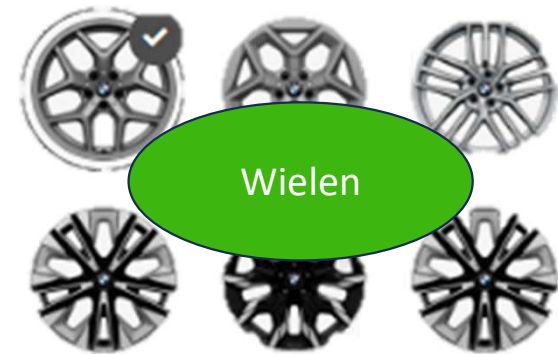

Wielen



Machinebouw

12 december 2023, Congrescentrum 1931

# Wat is modulair bouwen?



## Machinebouw

12 december 2023, Congrescentrum 1931



# Wat is modulair bouwen?



## Machinebouw

12 december 2023, Congrescentrum 1931

Technische en economische optimalisatie voor  
machinebouw

=

Decentraal bouwen voor optimalisatie van  
modulaire productieprocessen



Machinebouw

12 december 2023, Congrescentrum 1931

# De voordelen voor de machinebouwer

- Tijdsbesparing
- Minder vakmensen nodig
- Veel diagnose mogelijkheden
- Snel een storing vinden, i.p.v. uren lang zoeken
- Flexibel bouwen



Machinebouw

12 december 2023, Congrescentrum 1931

# Hoe modulair bouwen?

Voorbeeld uit  
de praktijk



Machinebouw

12 december 2023, Congrescentrum 1931

 **WP: Wiring Point**

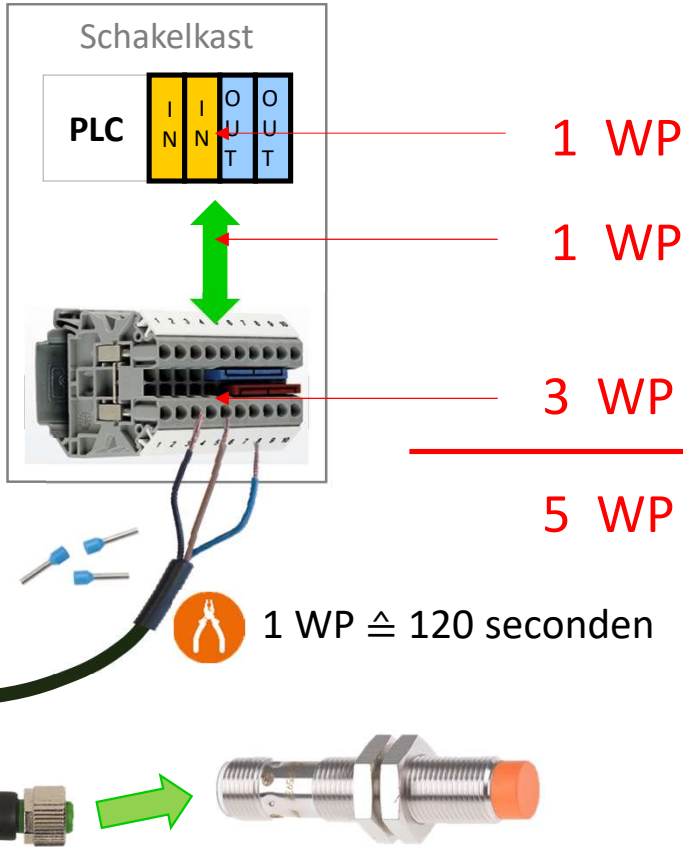

 **CP: Connection Point**



Aansluiten met voorgeconfectioneerde bekabeling

 1 CP  $\approx$  10 seconden



 **Machinebouw**

12 december 2023, Congrescentrum 1931

# Point to point aansluitingen

48 DI/16 DO  
306 klemaansluitingen  
64 M12 connecties  
10.31 uur

Difficulty Level

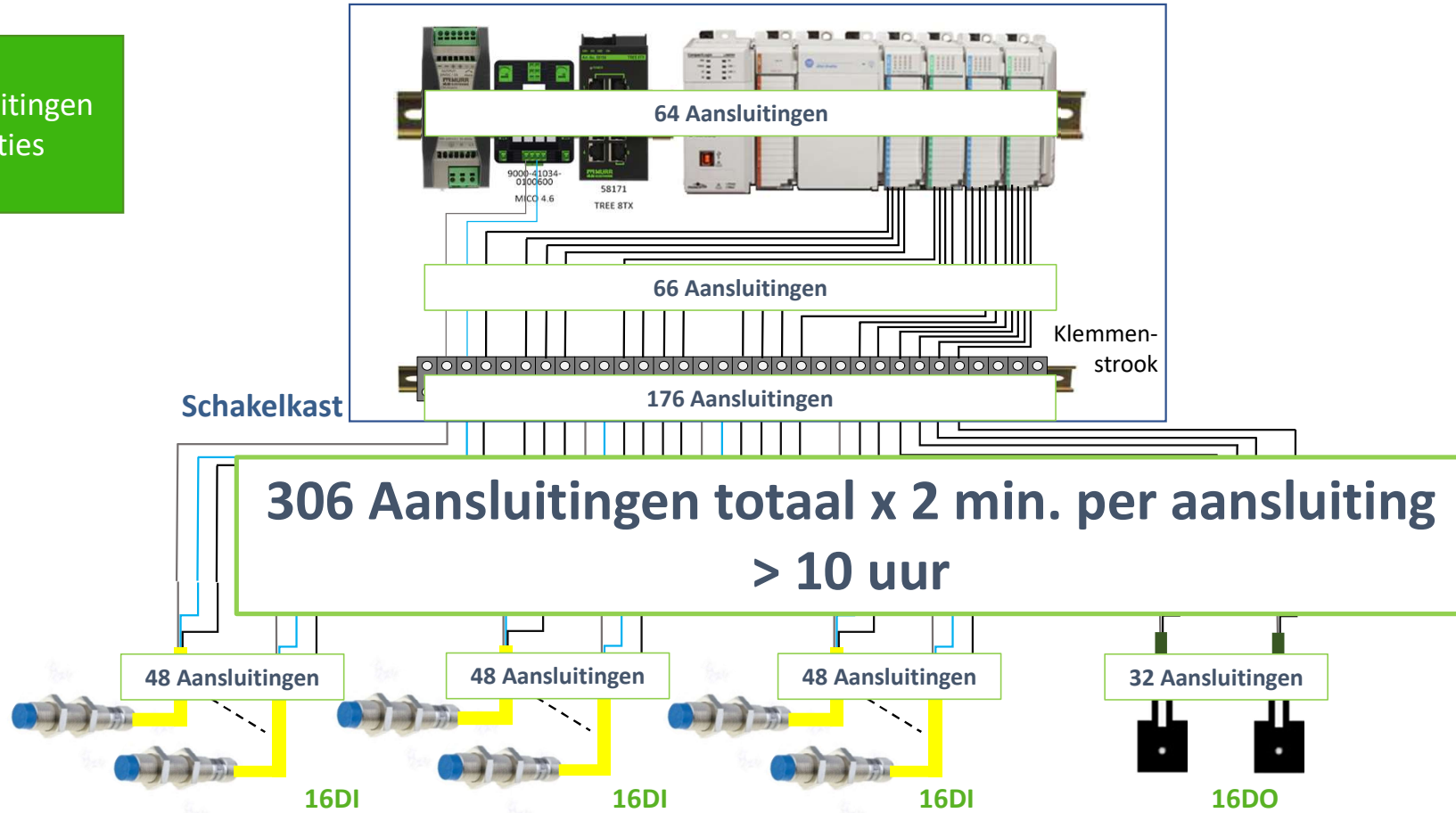

Machinebouw

12 december 2023, Congressentrum 1931

# Point to point – in de praktijk

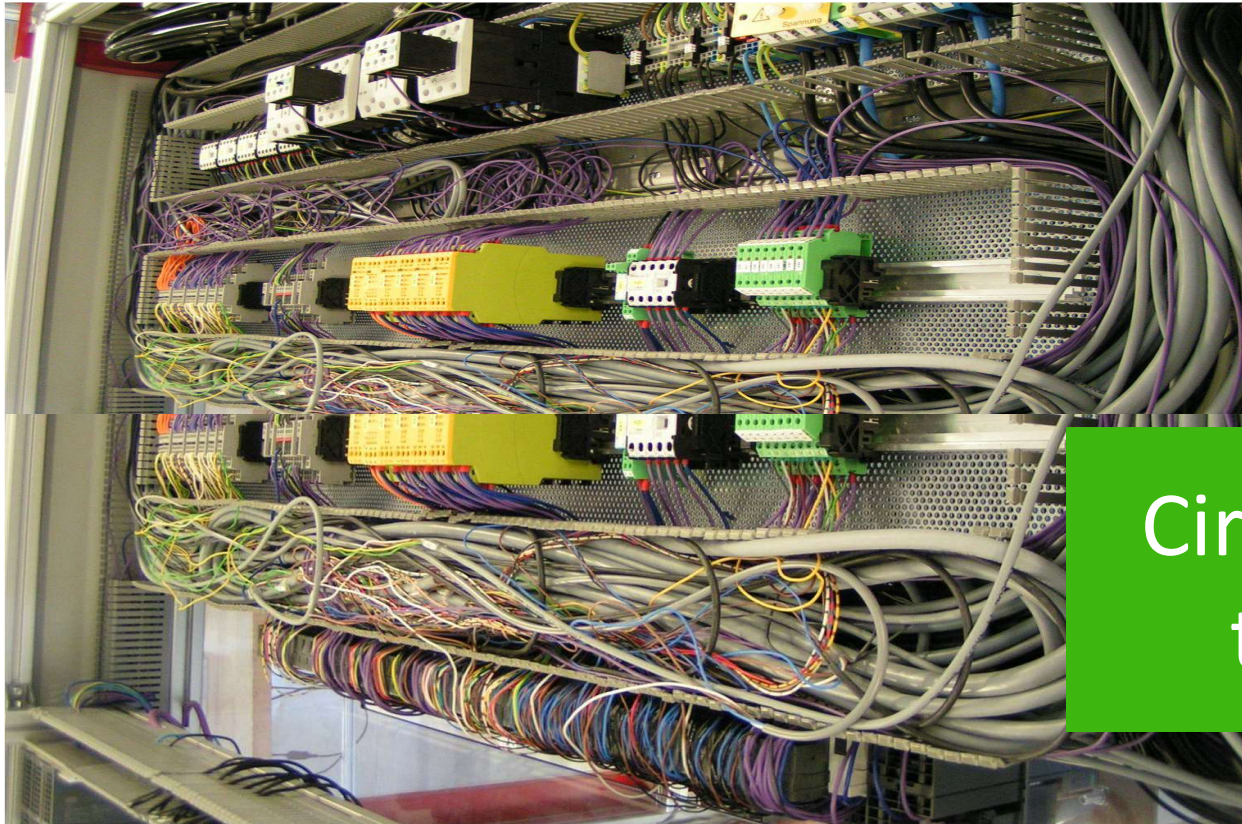

Circa 80% van alle  
toepassingen



● ● ●  
Machinebouw

12 december 2023, Congrescentrum 1931

# Actief decentraliseren

48 DI/16 DO  
306 klemaansluitingen  
64 M12 connecties  
10.31 uur

Difficulty Level

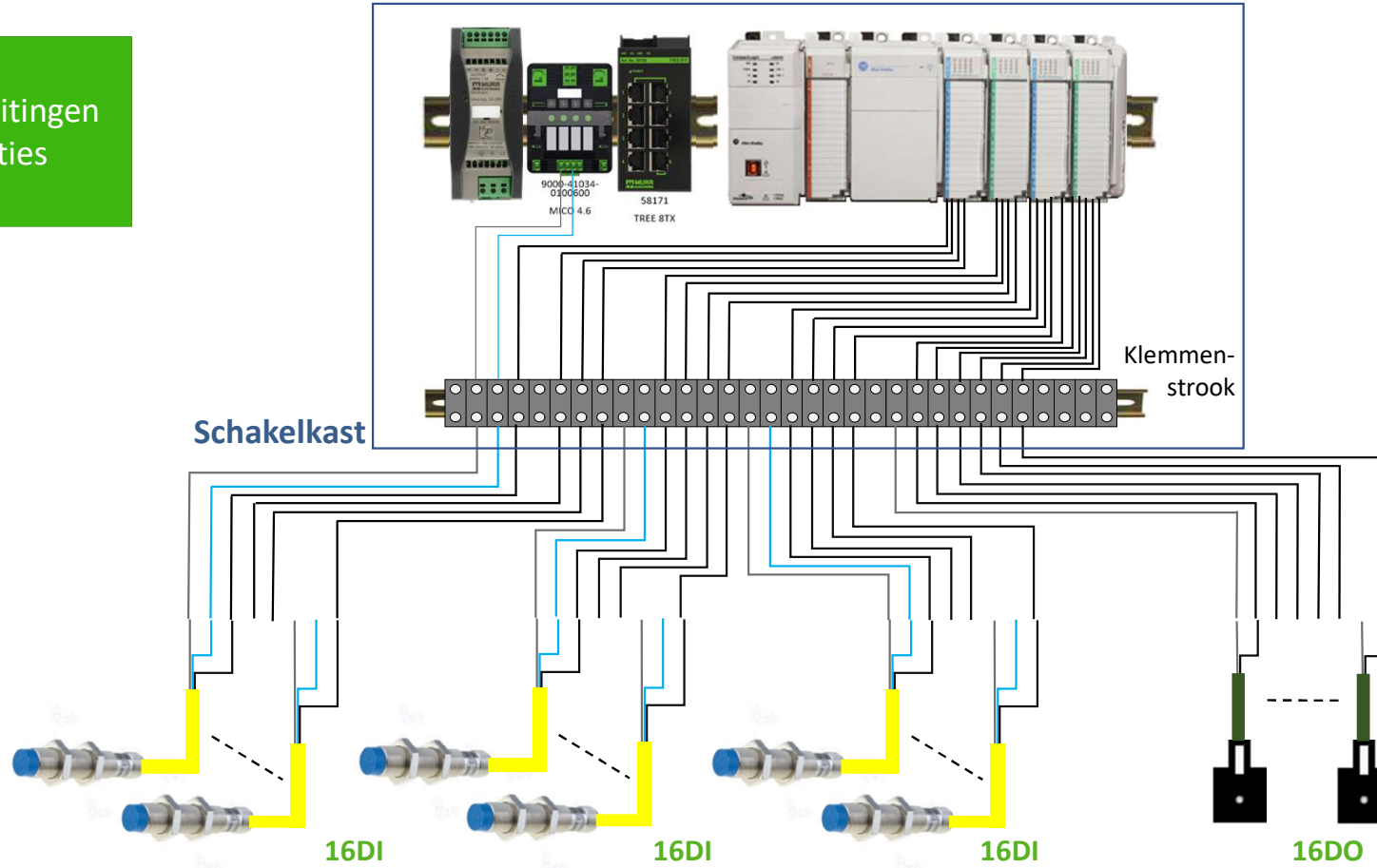

Machinebouw

12 december 2023, Congressentrum 1931



# Actief decentraliseren

48 DI/16 DO  
128 M12 Connections  
21.3 minuten

Difficulty Level



Schakelkast



128 M12 connecties  
Slechts 21 minuten!

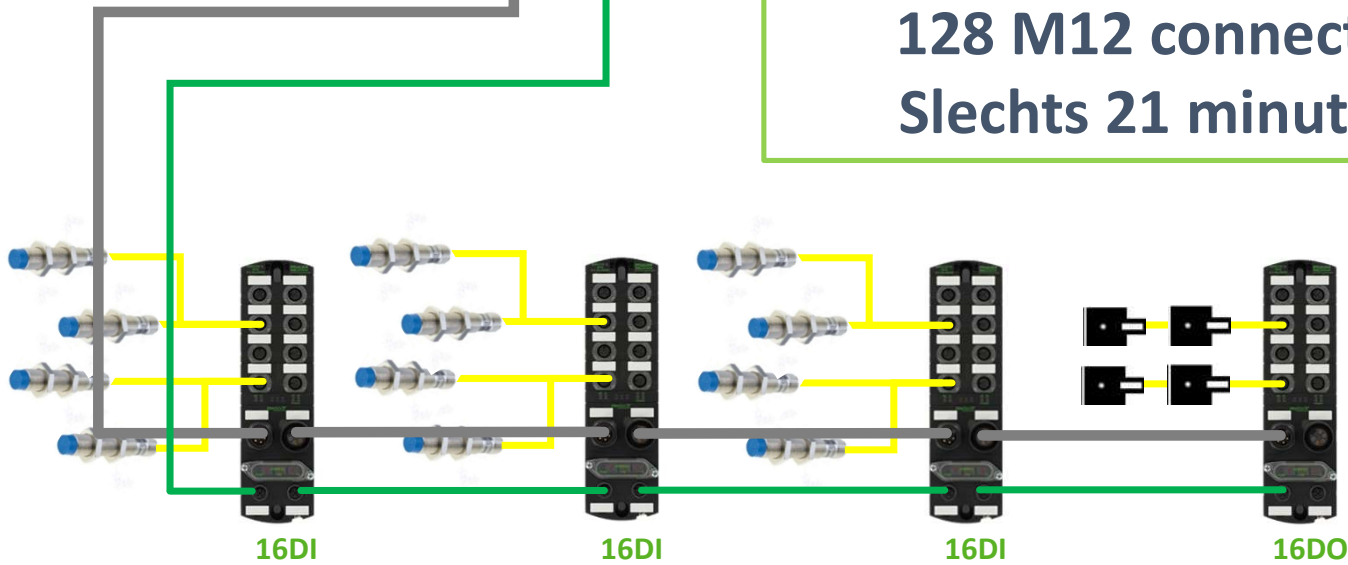

Machinebouw

12 december 2023, Congressentrum 1931

# De volgende stap in modulair bouwen

Kunnen we automatisering  
nog eenvoudiger maken?

Met een flexibel, schaalbaar en vooral open  
automatiseringsplatform dat oplossingen biedt op  
alle niveaus en via alle interfaces samenwerkt.

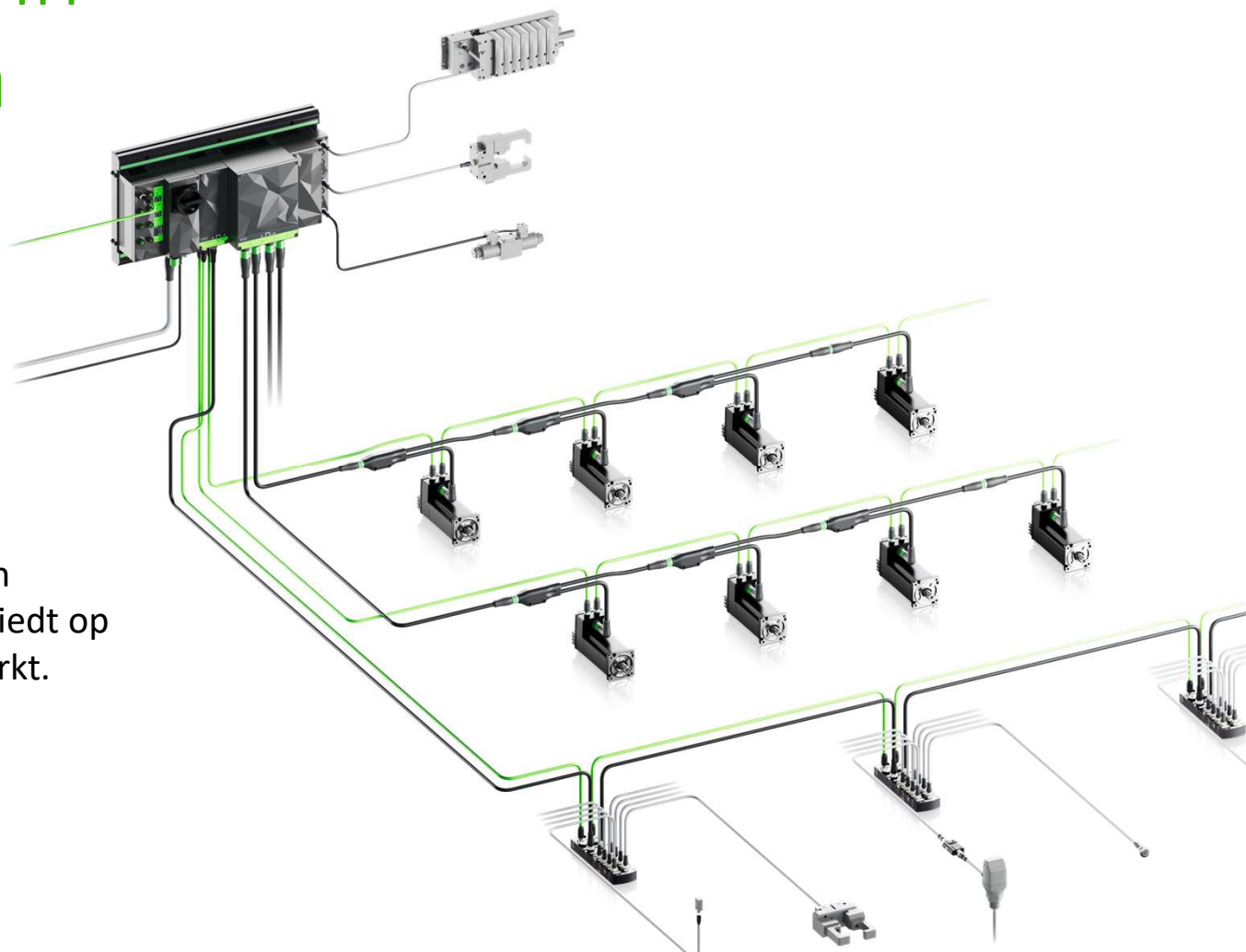

**Machinebouw**

12 december 2023, Congrescentrum 193



**VRAGEN ?**



● Machinebouw

● 12 december 2023, Congrescentrum 1931